

VTC 6100

Intel® Atom™ N270 Fanless In-vehicle Computer



VTC 6100 with optional IP65 enclosure



Main Features

- ♦ Build-in Intel® Atom™ N270 processor
- ♦ Availability of GSM/GPRS/WCDMA/HSDPA/GPS
- ♦ e13 mark certification
- ♦ External smart battery back up support
- ♦ Power ignition on/off delay control
- ♦ Circuitry design for low power protection
- ♦ 6~36V DC power input
- ♦ 1 PCI-104 expansion slot
- ♦ Multiple display interface connections (VGA, DVI-D and LVDS)
- ♦ Optional IP65 enclosure

Product Overview

The VTC 6100 is an innovative in-vehicle computer for use in any car, truck, or even for maritime applications. The design itself makes the system available as a complete system allowed the user easily define and build requirements. Thanks to the extremely-low power consumption nature from Intel® Atom™ processor, the VTC 6100 mechanical design is even more compact yet reach wider operating temperature range than ever. The VTC 6100 fulfills vehicle industry requirements. The design itself is in compliance with vehicle industrial standard such as eMark. More features required for in-vehicle operations, such as power ignition delay control, low-power protection and SMBus connection, etc., are continued from others of NEXCOM's in-vehicle computer products. The GPS function navigates drivers to ultimate the fleet management. Optional 802.11b/g/n, 3.5G, and Bluetooth availability make the VTC 6100 ready for wider coverage and future trend. Multiple display connections make the VTC 6100 an ideal choice for in-vehicle signage platforms as well.

Specifications

Main Chipset

- ♦ 945 GSE + ICH-7M

CPU

- ♦ Intel® Atom™ N270 1.6GHz

Memory

- ♦ DDR2 667 SO-DIMM up to 2GB

Expansion

- ♦ 1 x PCI-104
- ♦ 1 x Bluetooth module (optional)
- ♦ 2 x Mini-PCI express socket

I/O Interface-Front

- ♦ 4 x SMA Antenna holes for WLAN, HSDPA, Bluetooth
- ♦ 1 x Power button
- ♦ 1 x Reset switch
- ♦ 1 x SIM socket
- ♦ 1 x USB
- ♦ 4 x LED's for Stand-by, HDD, WLAN/HSDPA and GPIO
- ♦ 1 x Mic-in & 1 x Line-out

I/O Interface-Rear

- ♦ 2 x RS232
- ♦ 1 x RS232/485 w/ auto flow control
- ♦ 1 x DB26 LVDS (w/ +12V for backlight power & USB2.0)
- ♦ 1 x DB15 VGA
- ♦ 1 x DVI-D
- ♦ 2 x USB2.0
- ♦ 1 x 10/100/1000 Ethernet
- ♦ 1 x Mic-in & 1 Line-out
- ♦ 1 x SMA antenna hole for GPS
- ♦ 1 x GPIO (4 input & 4 output)
- ♦ 6V~36V DC thru 3-pin connector (ignition, power & ground)
- ♦ +5V/+12V DC output, SMBus
5V DC (1A), 12V DC (1A), without VTK 33M-01
5V DC (0.5A), 12V DC (0.5A), with VTK 33M-01

Expandable Storage

- ♦ 1 x 2.5" SATA II HDD + 1 x CF

Dimension Drawing

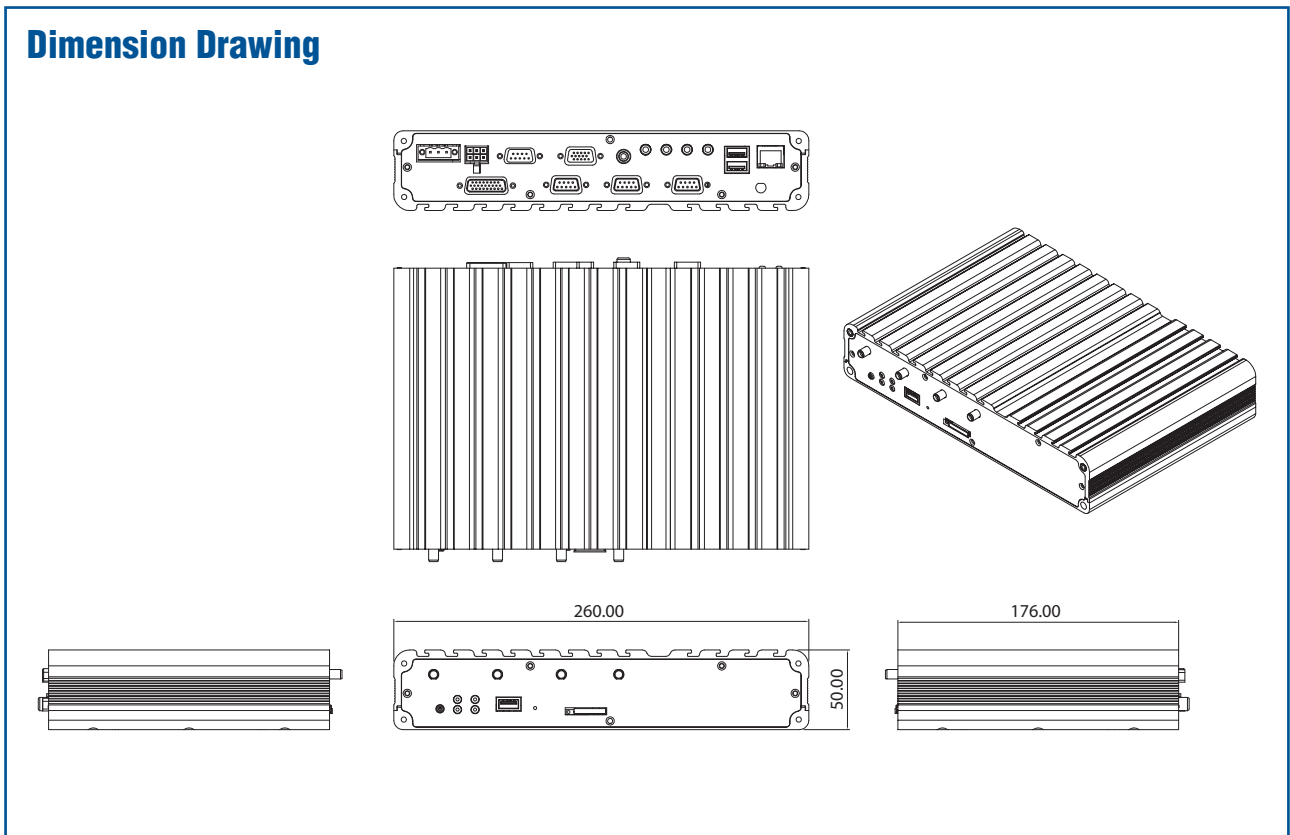

Power Management

- Boot-up & shut-down voltage setting selectable for low power protection by software
- Setting 8-level on/ off delay time by software
- Status of ignition and low voltage status can be detected by software

IP Rating

- IP65 compliant (w/ VTK 61P)

Dimensions

- 260mm (W) x 176mm (D) x 50mm (H) (10.24" x 6.93" x 1.97")
- 2.42 Kg (5.34 Lb)

Construction

- Aluminum enclosure with fanless design

Environment

- Operating temperature: -30°C to +60°C with CF or Automotive HDD
- Storage temperature -40°C to +80°C@relative humidity 10% to 90% non-condensing
- Vibration (w/o vibration kit): 2G@5-500Hz random with CF 1G@5-500Hz random with Automotive HDD MIL-STD-810F Method 514.5 Category 20 Ground Vehicle-Highway Truck (in operation)
- Shock: Operating: MIL-STD-810F Method 516.5, Procedure I, Trucks and semi-trailers=20g Non-Operating: MIL-STD-810F, Method 516.5, Procedure V, Ground equipment=75g

Certifications

- CE approval
- FCC Class B
- e13 Mark
- EN50155

Ordering Information

- **VTC 6100 (P/N: 10V00610000X0)**
Intel® Atom™ N270 1.6GHz processor & 1GB DDR2 memory & GPS module & GPS antenna
- **VTC 6100-DK (P/N: 10V00610011X0)**
Intel® Atom™ N270 1.6GHz processor, 1GB DDR2 memory, dead reckoning GPS module and GPS antenna

Optional Accessories

Part No.	Description
10VD010000X0	VMD 1000-B 7" monitor w/ touch screen
10VK33M0100X0	VTK 33M-01 8.4" monitor w/ touch screen
10VK0033V00X0	VTK 33V, anti-vibration/ fan kit
10VK0061B00X0	VTK 61B, back-up battery kit for 4 hours in system full loading
10VK0060P00X0	VTK 60P, IP65 protection kit for VTC 6000
10VK0061P00X0	VTK61P, IP65 protection kit for VTC 61XX series & VTC6200-NI
10Z00330200X0	NAK 3302, GSM/GPRS mini-PCIe card module for VTC6 xxx & VTC2 xxx series
10VK0006013X0	Wireless mini card kit, Ralink 802.11b/g/n 2T2R, QCOM: Q802XKN5F, w/ antenna & cable (without assembly in NEXCOM)
10VK0006000X0	Sierra MC8790V kit, GPRS/ UMTS/ HSDPA, w/ internal cable, antenna & packing (without assembly in NEXCOM)
10VK0006007X0	Bluetooth kit, QCOM: QBTM400-01 (V7), w/ antenna & cable (without assembly in NEXCOM)
10VK0006004X0	GPS kit, GlobalSat: EM-313 w/ antenna & cable (without assembly in NEXCOM)
7400120002X00	Power adapter FSP:120-AAB (N09001),120W 19V/ 6.3A
60233SAM03X00	Internal cable for GSM/ WLAN/ GPS antenna connection MOQ: 20 pcs
60233SAM05X00	GPS antenna/ 5m/ SMA180P
60233SAM07X00	GSM/GPRS antenna, SMA, support 850/ 900/ 1800/ 1900
60233SMA30X00	GPS+GSM combo antenna 5M/ SMA180P
60233SAM17X00	GPRS/ UMTS/ HSDPA antenna, SMA, support 850/ 900/ 1800/ 1900/ 2100