

S1722R

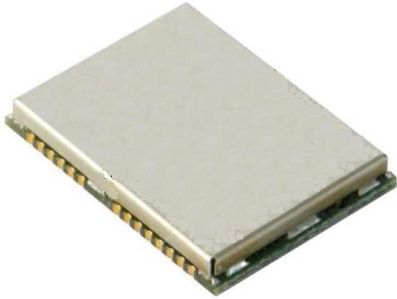

Features

- 65 Channel GPS L1 C/A Code
- Perform 8 million time-frequency hypothesis testing per second
- Open sky hot start 1 sec
- Open sky cold start 29 sec
- Cold start sensitivity -148dBm
- Tracking sensitivity -165dBm
- Multipath detection and suppression
- Jamming detection and mitigation
- Accuracy 2.5m CEP
- Maximum update rate 20Hz
- Tracking current ~28mA
- Supports active and passive antenna
- Operating temperature -40 ~ +85°C
- RoHS compliant

Applications

- PND
- MID / Netbook
- Smart-Phone
- Geo-Tagging
- Automatic Vehicle Location
- Personal Tracking

S1722R ROM-based

Low-Power High-Performance Low-Cost 65 Channel SMD GPS Module

The S1722R is a compact form factor GPS module solution intended for a broad range of OEM products, where fast and easy system integration and minimal development risk is required. The user only need to provide DC power of 3.0V ~ 3.6V and GPS signal; the S1722R will output navigation solution in standard NMEA-0183 protocol format.

The S1722R features 65 channel GPS receiver with fast time to first fix and improved -148dBm cold start sensitivity. The superior cold start sensitivity allows it to acquire, track, and get position fix autonomously in difficult weak signal environment. The receiver's -165dBm tracking sensitivity allows continuous position coverage in nearly all application environments. The high performance search engine is capable of testing 8,000,000 time-frequency hypotheses per second, offering industry-leading signal acquisition and TTFF speed.

Measuring 17mm x 22mm, the S1722R contains integrated LNA, SAW filter, 0.5ppm TCXO, 65 channel positioning engine, RTC crystal, and low-leakage backup supply LDO regulator. The RF section has cascaded noise figure of 1.2dB, allowing passive antenna operation without extra external LNA.

The receiver is optimized for applications requiring high performance, low power, and low cost; suitable for a wide range of OEM configurations including mobile phone, PND, asset tracking, and vehicle navigation products.

The metal RF shielding provides protection and allows standard surface mount device pick-and-place process in fully automated assembly process; enabling high-volume, very cost-efficient production. The S1722R is available in tape-and-reel form.

TECHNICAL SPECIFICATIONS

Receiver Type	L1 C/A code, 65-channel Venus 6 engine
Accuracy	Position 2.5m CEP Velocity 0.1m/sec Time 60ns
Startup Time	1 second hot start under open sky < 29 second warm start under open sky (average) 29 second cold start under open sky (average)
Reacquisition	1s
Sensitivity	-148dBm cold start -165dBm tracking
Multi-path Mitigation	Advanced multi-path detection and suppression
A-GPS	Support PromptFix® AGPS
Update Rate	Supports 1 / 2 / 4 / 5 / 8 / 10 / 20 Hz update rate (1Hz default)
Dynamics	4G (39.2m/sec ²)
Operational Limits	Altitude < 18,000m or velocity < 515m/s
Serial Interface	3.3V LVTTTL level
Protocol	NMEA-0183 V3.01 GPGGA, GPGLL, GPGSA, GPGSV, GPRMC, GPVTG* ¹ 9600 baud, 8, N, 1
Datum	Default WGS-84 User definable
Input Voltage	3.3V DC +/-10%
Input Current	~28mA tracking
Dimension	17mm L x 22.4mm W
Weight:	2g
Operating Temperature	-40°C ~ +85°C
Storage Temperature	-55 ~ +100°C
Humidity	5% ~ 95%

*1: GPGGA, GPGSA, GPGSV, GPRMC, GPVTG are default output message

BLOCK DIAGRAM

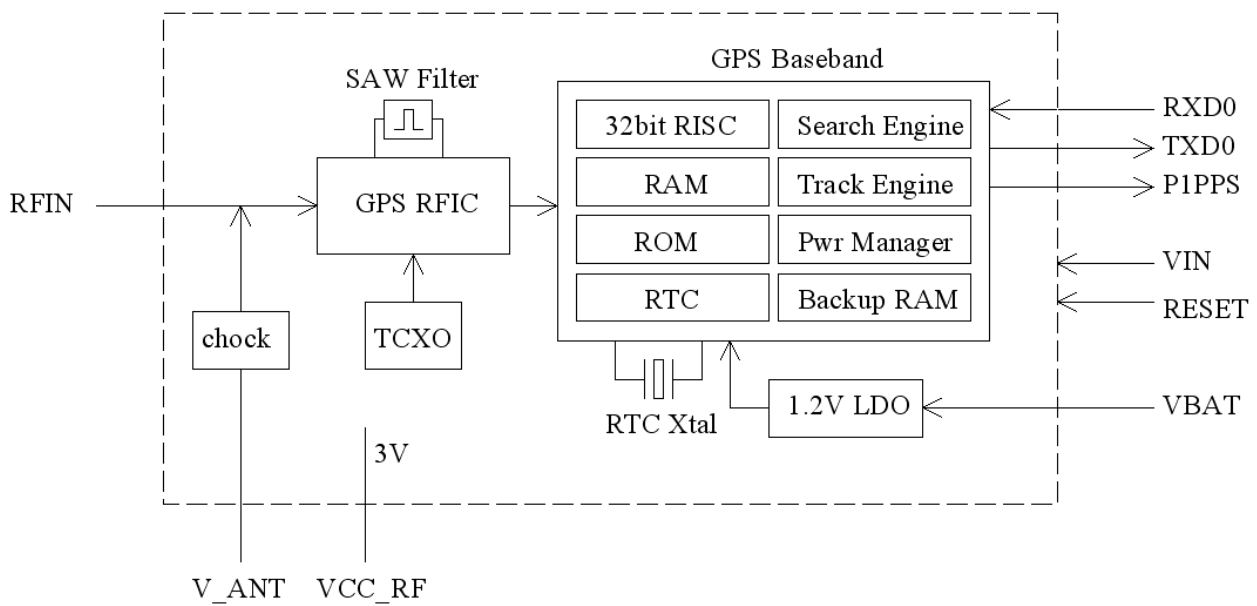

Module block schematic

The S1722R is a high performance GPS receiver in a compact surface mount package. It is based on the SkyTraq Venus 6 positioning technology, providing exceptional signal acquisition performance, and continuous operation even in dense foliage and urban canyons. The module includes internal SAW filter and high performance integrated LNA, works with both active and passive antenna. The simple UART serial interface and the standard NMEA-0183 protocol make using S1722R very easy and straightforward.

The S1722R performs all the necessary system initialization, satellite signal acquisition & tracking, data demodulation, and calculation of navigation solution autonomously. The position, velocity, time information in NMEA format is generated at user selectable update rate of 1 / 2 / 4 / 5 / 8 / 10 / 20 Hz.

MECHANICAL CHARACTERISTICS

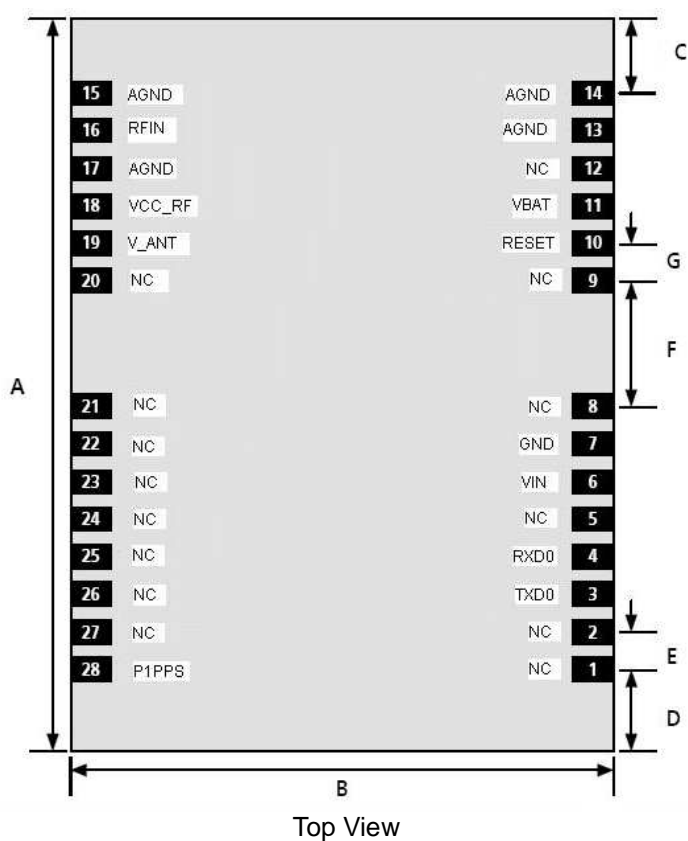

A	22.4mm
B	17.0mm
C	2.85mm
D	2.55mm
E	1.1mm
F	3.8mm
G	1.1mm

PINOUT DESCRIPTION

Pin No.	Name	Description
1,2	NC	No connection
3	TXD0	UART serial data output, 3V LVTTL. One full-duplex asynchronous serial UART port is implemented. This UART output is normally used for sending position, time and velocity information from the receiver in NMEA-0183 format. When idle, this pin output HIGH.
4	RXD0	UART serial data input, 3V LVTTL. One full-duplex asynchronous serial UART port is implemented. This UART input is normally for sending commands or information to the receiver in SkyTraq binary protocol. In the idle condition, this pin should be driven HIGH. If the driving circuitry is powered independently of S1722R, ensure that this pin is not driven to HIGH when primary power to S1722R is removed, or a 10K-ohm series resistor can be added to minimize leakage current from application to the powered off module.
5	NC	No connection
6	VIN	Main power supply, 3.0V ~ 3.6V DC
7	GND	System ground
8,9	NC	No connection
10	RESET	External active-low reset input. Only needed when power supply rise time is very slow or software controlled reset is desired.
11	VBAT	Backup supply voltage for internal RTC and backup SRAM, 1.5V ~ 6V. VBAT must be applied whenever VIN is applied. This pin should be powered continuously to minimize the startup time. If VIN and VBAT are both removed, the receiver will be in factory default mode upon power up, all user configuration set is lost. For applications the does not care cold starting every time, this pin can be connect to VIN.
12	NC	No connection
13,14,15	AGND	RF ground
16	RFIN	GPS RF input, connect to antenna
17	AGND	RF ground
18	VCC_RF	3V DC supply output from the RF section, can be connected to V_ANT to power 3V active antenna
19	V_ANT	Active antenna DC bias voltage input
20,21,22,23, 24,25,26,27	NC	No connection
28	P1PS	One-pulse-per-second (1PPS) time mark output, 3V LVTTL. The rising edge synchronized to UTC second when getting 3D position fix. The pulse duration is about 4msec at rate of 1 Hz.

ELECTRICAL SPECIFICATIONS

ABSOLUTE MAXIMUM RATINGS

Parameter	Minimum	Maximum	Condition
Supply Voltage (VIN)	-0.5	3.6	Volt
Backup Battery Voltage (VBAT)	-0.5	3.6	Volt
Input Pin Voltage	-0.5	VCC+0.5	Volt
Input Power at RFIN		+5	dBm
Storage Temperature	-55	+100	degC

OPERATING CONDITIONS

Parameter	Min	Typ	Max	Unit
Supply Voltage (VIN)	3	3.3	3.6	Volt
Acquisition Current (exclude active antenna current)			70	mA
Tracking Current (exclude active antenna current)		28		mA
Backup Voltage (VBAT)	1.5		6	Volt
Backup Current (VIN voltage applied)			1.5	mA
Backup Current (VIN voltage off)			10	uA
Output Low Voltage			0.4	Volt
Output HIGH Voltage	2.4			Volt
Input LOW Voltage			0.8	Volt
Input HIGH Voltage	2			Volt
Input LOW Current	-10		10	uA
Input HIGH Current	-10		10	uA
RF Input Impedance (RFIN)		50		Ohm

APPLICATION CIRCUIT

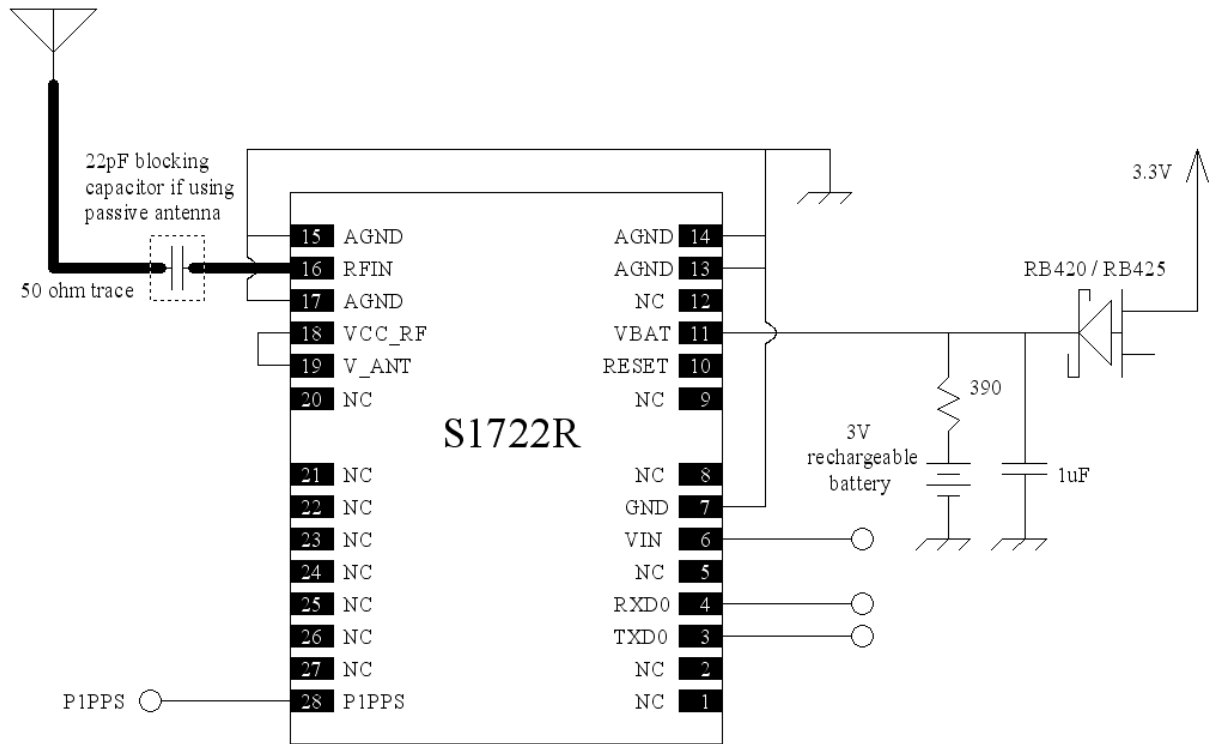

RECOMMENDED FOOTPRINT

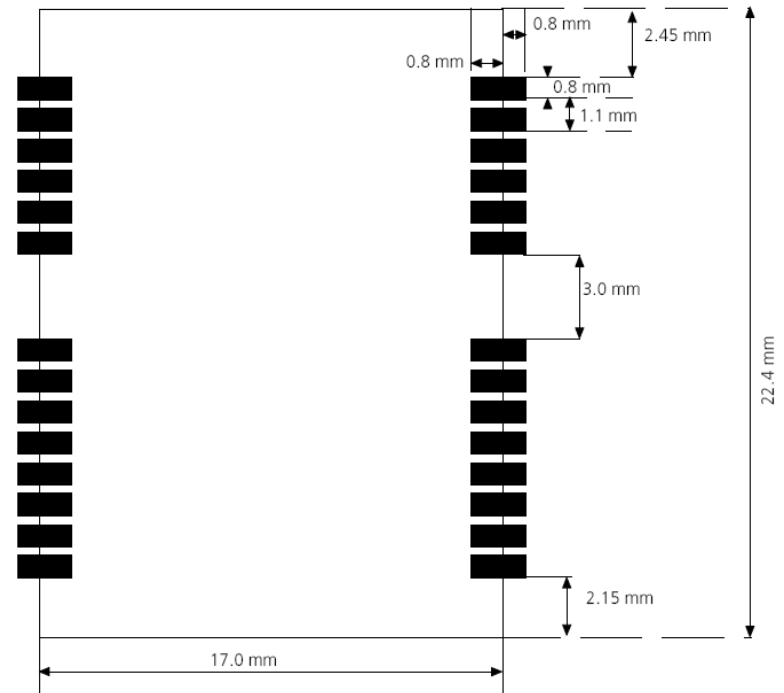

RECOMMENDED REFLOW PROFILE

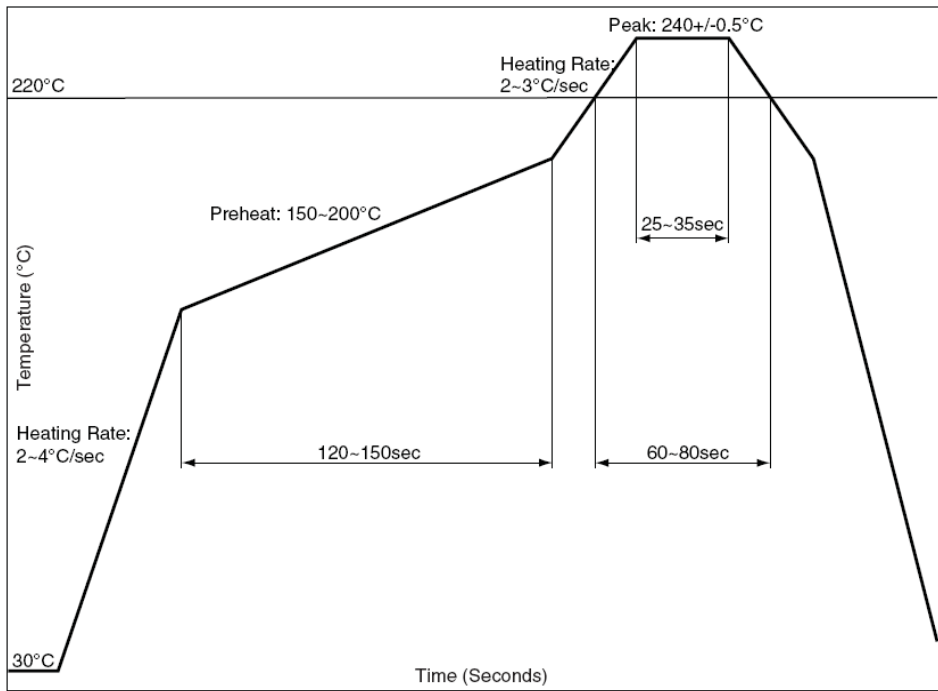

The reflow profile shown above should not be exceeded, since excessive temperatures or transport times during reflow can damage the module. Cooling temperature fall rate: max 3°C / sec

ANTENNA CONSIDERATIONS

The S1722R is designed to use with a wide variety of active and passive antennas, but care must be taken during antenna selection to ensure optimum signal reception performance. There are many choices of antenna configurations; the best choice is often a tradeoff between size, gain, bandwidth and cost. The best way is to test multiple antenna solutions in the configuration of the final system to determine which provides the best overall performance.

Ceramic patch antenna is low-cost and provides good sensitivity. 50-ohm output ceramic patch antenna can be connected directly to RF input of the module. Usually the antenna and S1722R are mounted on opposite side of the PCB to reduce possibility of picking up digital noise. To improve signal reception performance, use larger ground plane under the patch antenna if possible; larger the ground plane, larger the overall antenna gain. The center frequency of the ceramic patch antenna changes with ground plane size. For optimal operation, center frequency needs to be 1575MHz when mounted on the PCB. It is usual to ask the ceramic patch antenna vendor to select or tune a patch antenna that best matches the customer PCB.

Active antenna is essentially a passive antenna with built-in LNA and a coaxial cable to connect the antenna to the module. It has the flexibility of being located remotely from the module, but requires antenna power. Active antenna usually costs more than passive patch antenna, but the performance in low signal environments is usually better. When using active antenna, an external bias choke inductor is used to provide DC bias for the active antenna. Active antenna with gain up to 30dB and noise figure less than 2dB can be used with S1722R.

Chip antenna is often desired for its small size. Matching element of the chip antenna needs to be designed-in according to the chip antenna datasheet. If application doesn't have a large ground plane as shown in the datasheet for the measured performance spec condition, testing will be needed to determine if it can provide acceptable performance with the smaller sized application PCB.

The signal path from antenna to RF input of S1722R is the most critical part of application design. The goal is to provide optimal 50-ohm match between a 50Ω antenna and the module 50-ohm RF input for maximum power transfer. The 50-ohm grounded coplanar wave guide, consisting of the RF input signal with RF ground on either sides and a RF ground underneath, is a good choice for efficiency.

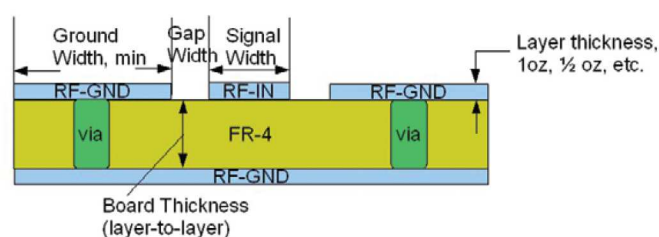

For a two-layer FR4 PCB design with 1.6mm thickness, 4.6 dielectric constant, and 1oz copper the RF-input trace should be 31mil in width, the gap to the adjacent grounds should be 6mil, and each of the RF grounds should be at least twice the width of the input signal trace (62mil). Freeware program such as AppCAD can be used to calculate values required for other configurations.

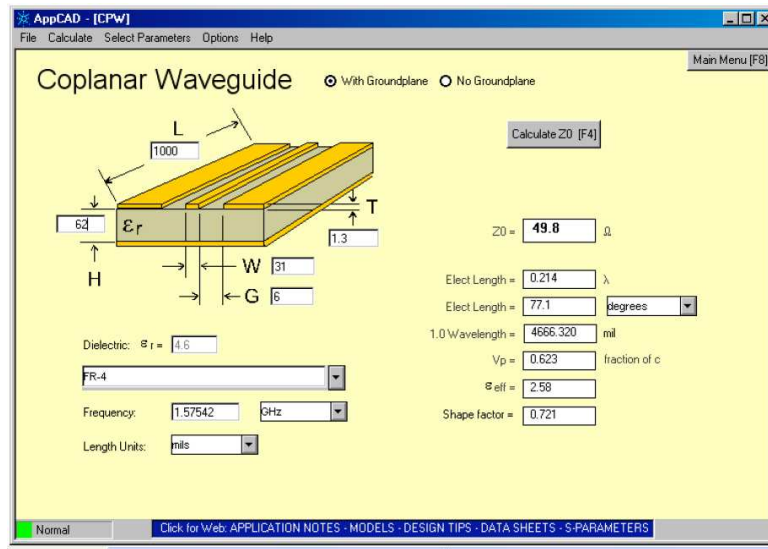

POWER SUPPLY REQUIREMENT

S1722R requires a stable power supply, avoid ripple on VIN pin (<50mVpp). Power supply noise can affect the receiver's sensitivity. Bypass capacitors should be placed close to the module VIN pin, with values adjusted depending on the amount and type of noise present on the supply line.

BACKUP SUPPLY

The purpose of backup supply voltage pin (VBAT) is to keep the SRAM memory and the RTC powered when the module is powered down. This enables the module to have a faster time-to-first-fix when the module is powered on again. The backup current drain is less than 10 μ A. In normal powered on state, the internal processor access the SRAM and current drain is higher in active mode

1PPS OUTPUT

A 1 pulse per second signal (4ms HIGH duration) is generated on 1PPS pin when the receiver has 3D position fix using 4 or more satellites. The rising edge of the pulse is aligned with UTC second, with accuracy of about 300nsec. It outputs constant LOW when no position fix is available.

LAYOUT GUIDELINES

Separate RF and digital circuits into different PCB regions.

It is necessary to maintain 50-ohm impedance throughout the entire RF signal path. Try keeping the RF signal path as short as possible.

Do not route the RF signal line near noisy sources such as digital signals, oscillators, switching power supplies, or other RF transmitting circuit. Do not route the RF signal under or over any other components (including S1722R), or other signal traces. Do not route the RF signal path on an inner layer of a multi-layer PCB to minimize signal loss.

Avoid sharp bends for RF signal path. Make two 45-deg bends or a circular bend instead of a single 90-degree bend if needed.

Avoid vias with RF signal path whenever possible. Every via adds inductive impedance. Vias are acceptable for connecting the RF grounds between different layers. Each of the module's ground pins should have short trace tying immediately to the ground plane below through a via.

The bypass capacitors should be low ESR ceramic types and located directly adjacent to the pin they are for.

NMEA MESSAGES

The full descriptions of supported NMEA messages are provided at the following paragraphs.

GGA - Global Positioning System Fix Data

Time, position and fix related data for a GPS receiver.

Structure:

```
$GPGGA,hhmmss.sss,ddmm.mmmm,a,dddmm.mmmm,a,x,xx,x.x,x.x,M,,,,,xxx*hh<CR><LF>
```

1
2
3
4
5 6 7 8 9
10 11

Example:

```
$GPGGA,111636.932,2447.0949,N,12100.5223,E,1,11,0.8,118.2,M,,,,,0000*02<CR><LF>
```

Field	Name	Example	Description
1	UTC Time	111636.932	UTC of position in hhmmss.sss format, (000000.000 ~ 235959.999)
2	Latitude	2447.0949	Latitude in ddm.dddmm format Leading zeros transmitted
3	N/S Indicator	N	Latitude hemisphere indicator, 'N' = North, 'S' = South
4	Longitude	12100.5223	Longitude in dddmm.mmmm format Leading zeros transmitted
5	E/W Indicator	E	Longitude hemisphere indicator, 'E' = East, 'W' = West
6	GPS quality indicator	1	GPS quality indicator 0: position fix unavailable 1: valid position fix, SPS mode 2: valid position fix, differential GPS mode 3: GPS PPS Mode, fix valid 4: Real Time Kinematic. System used in RTK mode with fixed integers 5: Float RTK. Satellite system used in RTK mode. Floating integers 6: Estimated (dead reckoning) Mode 7: Manual Input Mode 8: Simulator Mode
7	Satellites Used	11	Number of satellites in use, (00 ~ 12)
8	HDOP	0.8	Horizontal dilution of precision, (00.0 ~ 99.9)
9	Altitude	108.2	mean sea level (geoid), (-9999.9 ~ 17999.9)
10	DGPS Station ID	0000	Differential reference station ID, 0000 ~ 1023 NULL when DGPS not used
11	Checksum	02	

GLL – Latitude/Longitude

Latitude and longitude of current position, time, and status.

Structure:

\$GPGLL,ddmm.mmmm,a,dddmm.mmmm,a,hhmmss.sss,A,a*hh<CR><LF>
 1 2 3 4 5 6 7 8

Example:

\$GPGLL,2447.0944,N,12100.5213,E,112609.932,A,A*57<CR><LF>

Field	Name	Example	Description
1	Latitude	2447.0944	Latitude in ddmm.mmmm format Leading zeros transmitted
2	N/S Indicator	N	Latitude hemisphere indicator 'N' = North 'S' = South
3	Longitude	12100.5213	Longitude in dddmm.mmmm format Leading zeros transmitted
4	E/W Indicator	E	Longitude hemisphere indicator 'E' = East 'W' = West
5	UTC Time	112609.932	UTC time in hhmmss.sss format (000000.000 ~ 235959.999)
6	Status	A	Status, 'A' = Data valid, 'V' = Data not valid
7	Mode Indicator	A	Mode indicator 'N' = Data not valid 'A' = Autonomous mode 'D' = Differential mode 'E' = Estimated (dead reckoning) mode 'M' = Manual input mode 'S' = Simulator mode
8	Checksum	57	

GSA – GNSS DOP and Active Satellites

GPS receiver operating mode, satellites used in the navigation solution reported by the GGA or GNS sentence and DOP values.

Structure:

```
$GPGSA,A,x,xx,xx,xx,xx,xx,xx,xx,xx,xx,xx,xx,xx,x.x,x.x,x.x*hh<CR><LF>
  1 2 3 3 3 3 3 3 3 3 3 3 3 3 4 5 6 7
```

Example:

```
$GPGSA,A,3,05,12,21,22,30,09,18,06,14,01,31,,1.2,0.8,0.9*36<CR><LF>
```

Field	Name	Example	Description
1	Mode	A	Mode 'M' = Manual, forced to operate in 2D or 3D mode 'A' = Automatic, allowed to automatically switch 2D/3D
2	Mode	3	Fix type 1 = Fix not available 2 = 2D 3 = 3D
3	Satellite used 1~12	05,12,21,22,30,09,18,06,14,01,31,,	Satellite ID number, 01 to 32, of satellite used in solution, up to 12 transmitted
4	PDOP	1.2	Position dilution of precision (00.0 to 99.9)
5	HDOP	0.8	Horizontal dilution of precision (00.0 to 99.9)
6	VDOP	0.9	Vertical dilution of precision (00.0 to 99.9)
7	Checksum	36	

GSV – GNSS Satellites in View

Number of satellites (SV) in view, satellite ID numbers, elevation, azimuth, and SNR value. Four satellites maximum per transmission.

Structure:

```
$GPGSV,x,x,xx,xx,xx,xxx,xx,...,xx,xx,xxx,xx *hh<CR><LF>  
  1 2 3 4 5 6 7 4 5 6 7 8
```

Example:

```
$GPGSV,3,1,12,05,54,069,45,12,44,061,44,21,07,184,46,22,78,289,47*72<CR><LF>  
$GPGSV,3,2,12,30,65,118,45,09,12,047,37,18,62,157,47,06,08,144,45*7C<CR><LF>  
$GPGSV,3,3,12,14,39,330,42,01,06,299,38,31,30,256,44,32,36,320,47*7B<CR><LF>
```

Field	Name	Example	Description
1	Number of message	3	Total number of GSV messages to be transmitted (1-3)
2	Sequence number	1	Sequence number of current GSV message
3	Satellites in view	12	Total number of satellites in view (00 ~ 12)
4	Satellite ID	05	Satellite ID number, GPS: 01 ~ 32, SBAS: 33 ~ 64 (33 = PRN120)
5	Elevation	54	Satellite elevation in degrees, (00 ~ 90)
6	Azimuth	069	Satellite azimuth angle in degrees, (000 ~ 359)
7	SNR	45	C/No in dB (00 ~ 99) Null when not tracking
8	Checksum	72	

RMC – Recommended Minimum Specific GNSS Data

Time, date, position, course and speed data provided by a GNSS navigation receiver.

Structure:

```
$GPRMC,hhmmss.sss,A,dddmm.mmmm,a,dddmm.mmmm,a,x.x,x.x,ddmmyy,,,a*hh<CR><LF>
```

1 2 3 4 5 6 7 8 9 10 11

Example:

```
$GPRMC,111636.932,A,2447.0949,N,12100.5223,E,000.0,000.0,030407,,,A*61<CR><LF>
```

Field	Name	Example	Description
1	UTC time	0111636.932	UTC time in hhmmss.sss format (000000.00 ~ 235959.999)
2	Status	A	Status 'V' = Navigation receiver warning 'A' = Data Valid
3	Latitude	2447.0949	Latitude in dddmm.mmmm format Leading zeros transmitted
4	N/S indicator	N	Latitude hemisphere indicator 'N' = North 'S' = South
5	Longitude	12100.5223	Longitude in dddmm.mmmm format Leading zeros transmitted
6	E/W Indicator	E	Longitude hemisphere indicator 'E' = East 'W' = West
7	Speed over ground	000.0	Speed over ground in knots (000.0 ~ 999.9)
8	Course over ground	000.0	Course over ground in degrees (000.0 ~ 359.9)
9	UTC Date	030407	UTC date of position fix, ddmmyy format
10	Mode indicator	A	Mode indicator 'N' = Data not valid 'A' = Autonomous mode 'D' = Differential mode 'E' = Estimated (dead reckoning) mode 'M' = Manual input mode 'S' = Simulator mode
11	checksum	61	

VTG – Course Over Ground and Ground Speed

The Actual course and speed relative to the ground.

Structure:

GPVTG,x.x,T,,M,x.x,N,x.x,K,a*hh<CR><LF>
1 2 3 4 5

Example:

\$GPVTG, 000.0,T,,M,000.0,N,0000.0,K,A*3D<CR><LF>

Field	Name	Example	Description
1	Course	000.0	True course over ground in degrees (000.0 ~ 359.9)
2	Speed	000.0	Speed over ground in knots (000.0 ~ 999.9)
3	Speed	0000.0	Speed over ground in kilometers per hour (0000.0 ~ 1800.0)
4	Mode	A	Mode indicator 'N' = not valid 'A' = Autonomous mode 'D' = Differential mode 'E' = Estimated (dead reckoning) mode 'M' = Manual input mode 'S' = Simulator mode
5	Checksum	3D	

ORDERING INFORMATION

Model Name	Description
S1722R	ROM Version GPS receiver Module

The information provided is believed to be accurate and reliable. These materials are provided to customers and may be used for informational purposes only. No responsibility is assumed for errors or omissions in these materials, or for its use. Changes to specification can occur at any time without notice.

These materials are provided "as is" without warranty of any kind, either expressed or implied, relating to sale and/or use including liability or warranties relating to fitness for a particular purpose, consequential or incidental damages, merchantability, or infringement of any patent, copyright or other intellectual property right. No warrant on the accuracy or completeness of the information, text, graphics or other items contained within these materials. No liability assumed for any special, indirect, incidental, or consequential damages, including without limitation, lost revenues or lost profits, which may result from the use of these materials.

The product is not intended for use in medical, life-support devices, or applications involving potential risk of death, personal injury, or severe property damage in case of failure of the product.
