

IAP-W510

➤ **Industrial outdoor IEEE 802.11 a/n wireless access point with 1x10/100Base-T(X), IP-67 grade**

Features

- High Speed Air Connectivity: WLAN interface support up to 300Mbps link speed
- Highly Security Capability: WEP/WPA/WPA-PSK(TKIP,AES)/ WPA2/ WPA2-PSK(TKIP,AES)/802.1X Authentication supported
- **High throughput**
- **High power output of 500 mW**
- **Far Distance Air Connectivity up to 10 km**
- **Supports X-Roaming < 100 ms**
- **Supports wireless load balance**
- Supports AP/Bridge/Repeater/AP-Client/Client Mode
- Wireless connecting status monitoring
- HTTPs protocol supported for secured management
- Event Warning by Syslog, Email, SNMP Trap
- Rigid IP-67 housing design
- Pole and Wall-mount enabled



Introduction

IAP-W510 is a reliable IP-67 outdoor IEEE 802.11 a/n WLAN Access Point with 1 waterproof Ethernet port. It can be configured to operate in AP/Bridge/Repeater/AP-Client/Client mode. In combination with its IP-67 design and the superb management functionality, IAP-W510 is specifically designed for the toughest industrial environments and provides a waterproof, dust-tight connection. In addition, IAP-W510 provides high power output of 500mW and high throughput to satisfy far distance connection. You are able to configure IAP-W510 by WEB interface via LAN port or WLAN interface. The IAP-W510 can be easily adopted in almost all kinds of applications and provides the most rugged solutions for managing your network in outdoor. Therefore, IAP-W510 is one of the best outdoor communication solutions for wireless applications.

Application

In practical operation of wireless access point, Windows utility (AP-Tool) is supported. This utility is very helpful for you to search and configure IP of access point on the industrial wireless network. In addition, the wireless access point support various kinds of operation modes include AP/ Bridge/Repeater/AP-Client/Client mode. IAP-W510 also can connect to each other up to 10,000 meters with built-in panel antenna. You can build up the wireless network easily.

Various Kinds of Operation Modes

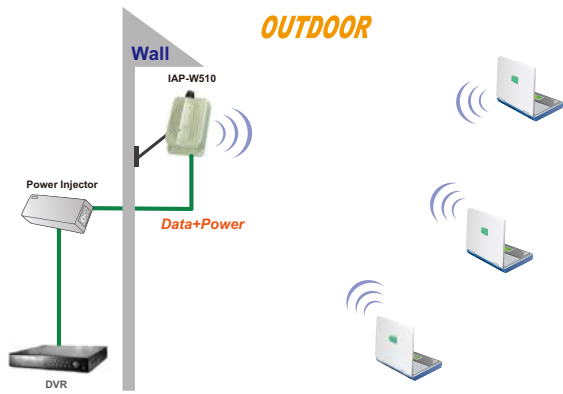

AP Mode

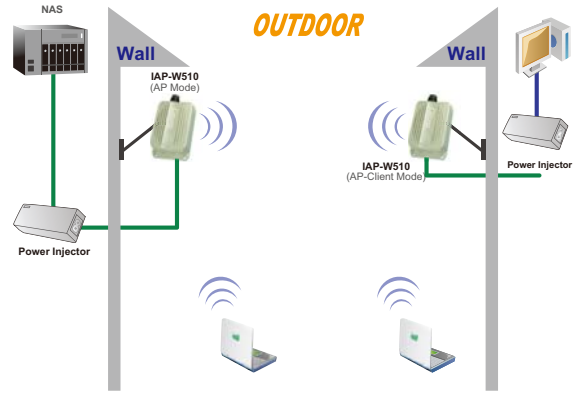

AP-Client Mode

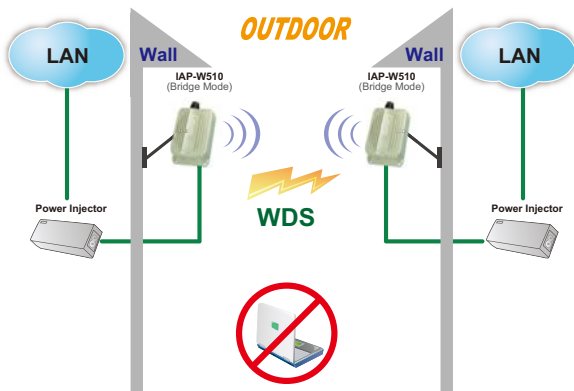

Bridge Mode

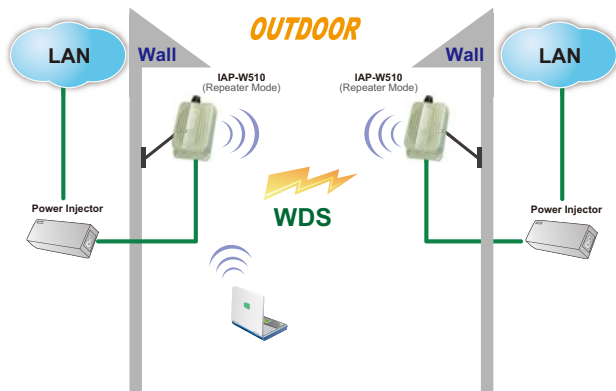

Repeater Mode

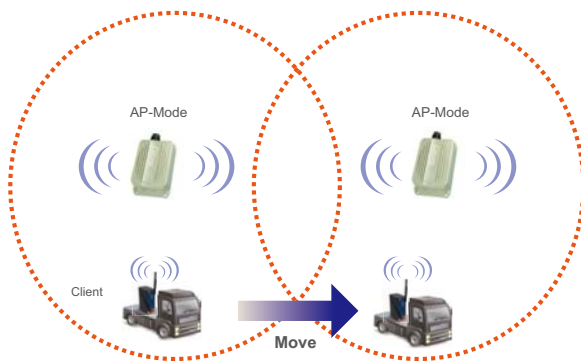

X-Roaming

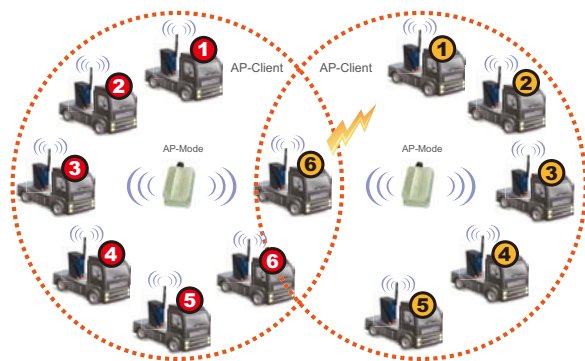

Wireless Load Balance

Dimensions

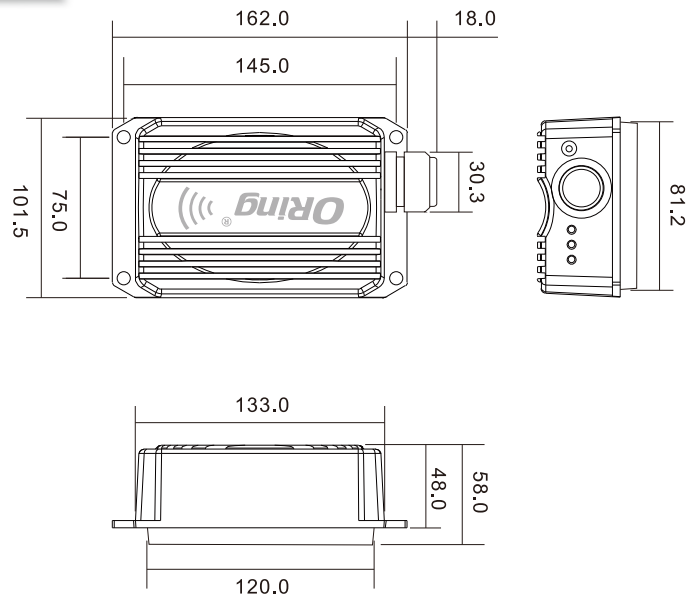

Unit=mm

Specifications

ORing WLAN Access Point Model	IAP-W510
Physical Ports	
10/100 Base-T(X) Ports in RJ45 Auto MDI/MDIX	1
WLAN interface	
Operating Mode	AP/Bridge/Repeater/AP-Client/Client
Antenna Connector	Built-in 15dBi panel antenna
Radio Frequency Type	OFDM
Modulation	IEEE802.11a : OFDM with BPSK, QPSK, QAM, 64QAM IEEE802.11n : BPSK, QPSK, 16-QAM, 64-QAM
Frequency Band	America / FCC : 5.15 to 5.825 GHz (13 channels) Europe CE / ETSI : 5.15 to 5.724 GHz (19 channels)
Transmission Rate	IEEE802.11a : 6/ 9/ 12/ 18/ 24/ 36/ 48/ 54 Mbps IEEE801.11n : 300Mbps
Transmit Power	IEEE802.11a/n: 500mW
Receiver Sensitivity	-82dBm @ 54Mbps, PER< 10%; -78dBm@MCS 15(11n, 20MHz), PER< 10%; -75dBm@MCS 15(11n, 40MHz), PER< 10%
Encryption Security	WEP : (64-bit , 128-bit key supported) WPA/WPA2 :802.11i(WEP and AES encryption) WPA-PSK (256-bit key pre-shared key supported) 802.1X Authentication supported TKIP encryption
Wireless Security	SSID broadcast disable
Protocol Support	
Protocol	ARP,BOOTP, DHCP, DNS , HTTPs, IP, ICMP, SNTP,TCP, UDP, RADIUS, SNMP, STP (IEEE 802.1D)
LED indicators	
Power indicator	PWR / Ready Green On: Power is on and functioning Normally.
10/100Base-T(X) RJ45 port indicator	Green On: Port Link Green Blinking: Transmitting data
WLAN LED	Green for WLAN Link/ Act

Power	
Input Power	48VDC on RJ45
Power Consumption (Typ.)	9 Watts
Physical Characteristics	
Enclosure	IP-67
Dimensions (W x D x H)	162(W)x 102(D)x 58(H) mm (6.38x 4.02x 2.28 inch.)
Weight (g)	680 g
Environmental	
Storage Temperature	-30 to 85°C (-22 to 185°F)
Operating Temperature	-20 to 70°C (-4 to 158°F)
Operating Humidity	0~100% Non-condensing
Regulatory Approvals	
EMI	FCC Part 15, CISPR (EN55022) class A
EMS	EN61000-4-2 (ESD), EN61000-4-3 (RS), EN61000-4-4 (EFT), EN61000-4-5 (Surge), EN61000-4-6 (CS), EN61000-4-8, EN61000-4-11
Shock	IEC60068-2-27
Free Fall	IEC60068-2-32
Vibration	IEC60068-2-6
Safety	EN60950-1
Warranty	3 years

Ordering Information

IAP-W **A** **B** 0

Code Definition	Wireless Mode	10/100Base-T(X) Port Number
Option	<ul style="list-style-type: none"> - 1: IEEE 802.11 b/g - 2: IEEE 802.11 a - 3: IEEE 802.11 a/b/g - 4: IEEE 802.11 b/g/n - 5: IEEE 802.11 a/n - 6: IEEE 802.11 a/b/g/n 	-" 1 ": 1 port

Available Model	Model Name	Description
	IAP-W510_US	Industrial outdoor IEEE 802.11 a/n wireless access point with 1x10/100Base-T(X), IP-67 grade, US band
	IAP-W510_EU	Industrial outdoor IEEE 802.11 a/n wireless access point with 1x10/100Base-T(X), IP-67 grade, EU band

Packing List

- IAP- W510
- Wall/Pole Mount Kit
- Power Injector
- ORing Tool CD
- Quick Installation Guide